

PCX系列高效锤式细碎机

PCX Series High Efficient Hammer Fine Crusher

PCX 高效细碎机，亦称反击高效细碎机，适用于破碎抗压强度不超过200MPa 的石灰石、泥灰岩、砂岩、页岩、石膏、煤等原料。

PCX 系列高效细碎机具有很大的破碎腔和进料口，适宜大块矿石顺利进入，与常规破碎机相比有着明显的优势。

PCX Series High Efficient Hammer Fine Crusher, also be called as Impact High Efficiency Fine Crusher, is suitable for crushing limestone, marlstone, sand stone, gypsum, coal, etc, of which the crushing compressive strength does not exceed 200MPa.

特点及优势 Features and Benefits:

- ⊙ 技术先进；
 - ⊙ 超高细碎：合理的多腔破碎室组合，新型的便捷双调节结构，出料粒度在 3mm 以下产品达到 85%，产品粒度细而均匀；
 - ⊙ 维修简单：便捷的检修维护装置，使调换锤头、筛板更加便捷；
 - ⊙ 超长寿命：磨损件均采用新型优质多元素高铬合金耐磨材料制造，保证了锤头，衬板优越的耐磨性和耐冲击性；
 - ⊙ 高效节能：本系列破碎机运转平稳、低尘、低电耗；
 - ⊙ 破碎比大，可将二、三级破碎合为一级破碎，破碎比可达 25-30.
 - ⊙ 高效细碎机锤头可以轮换 4 次使用，锤头寿命倍增，大大节省成本，提高了投资回报。
-
- ⊙ Advanced technology.
 - ⊙ Uper fine crushing: Reasonable multiple crushing chamber combination, new convenient double adjustment structure, the output size being smaller than 3mm can reach 85%, finished particle size is fine and uniform.
 - ⊙ Easy maintenance: Convenient inspection and maintenance device, which make hammer adjustment and screen plate become easier.
 - ⊙ Super long life: Wear-out part adopts new excellent multielement high chromium alloy which ensure abrasive resistance and shock resistance of the liner plate.
 - ⊙ High efficient Energy Consumption: This series crusher possesses stable operation, low dust, low power consumption.
 - ⊙ Large crushing ratio: Secondary crushing and tertiary crushing can be integrated as primary crushing, crushing ratio reaches 25-30.

PCX系列高效细碎机设备结构

Structure of PCX Series High Efficient Fine Crusher

本设备主要由上下壳体，转子部分，衬板，反击装置，锤头装置组成。转子部分的轴心上有多个重叠排列的锤架，锤头装置固定在锤架之间的穿杆上。主轴两端用滚动轴承座支承机架上。衬板分成若干块固定于箱体上，保护箱体不受磨损。箱体分为上下两部分，用螺栓连接，便于拆装和检修。

This equipment is composed of upper and lower case, rotor, liner, impact device, hammer head device. There are multiple overlapping arranged hammer carriers on the axis of rotor; hammer device is fixed on the rod among hammer carrier. Rolling bearing is used for supporting both ends of main axis on machine chassis. Liner plate is divided into several pieces fixing on cabinet, for protecting cabinet from abrasion. Cabinet is divided into upper and lower parts, connected by bolt, which is convenient for disassembling and maintenance.

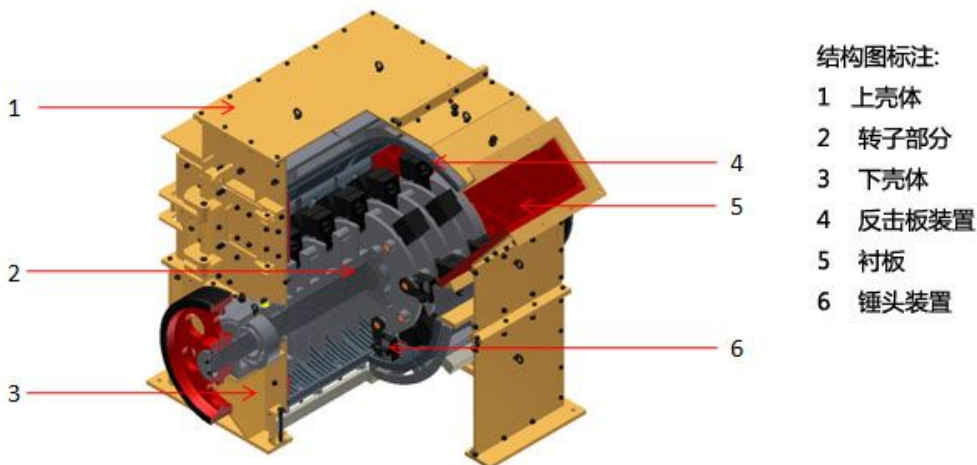

工作原理 working principle

物料从进料斗依次进入腔体内，下落在高速旋转的活动打击锤头上，经过锤头与反击板之间的作用，物料初步破碎在锤击区，物料多次受到高频的反复锤击和反击后下降在中隔板上，形成堆积，产生滑落，落在转子下面的筛板上，又被高速抛到反击板进行碰撞，下落并经移动式锤头强制性反击，破碎，研磨。因此，物料经过其自重下落过程中多次复合粉碎，冲刷研磨，从而实现了超细的效果。

Stones enter cavity from feed hopper, fall on high speed rotated impact hammer head, through effect between hammer head and impact plate, stones are primarily crushed on hammer part, stones fall on median septum after being hammered and impacted frequently, piled up, crept down on the screen plate which is below the rotor, then be threw to the impact plate for impacting, fall and be impacted mandatorily by mobile hammer head, crushed, grinded. Therefore, stones are crushed multiple times during gravity falling procedure, grinded, thus to realize ultrafine effect.

技术参数 Technical Data

型号 Model	最大进料 Max Feeding Size (mm)	平均出料 Average Discharging Size(mm)	处理能力 Capacity(tph)		电机功率 Motor Power (kw)	外形尺寸 Dimension (mm)
			水泥熟料 Cement Clinker	石灰石 Limestone		
PCX-8040	80	3	15-20	20-25	37	1395x1506x1390
PCX-8080	80	3	25-30	30-40	45	1395x1906x1390
PCX-9080	100	3	40-45	45-50	55	1754x1906x1659
PCX-9010	100	3	45-50	50-55	75	1754x2176x1659
PCX-1010	150	3-5	50-60	60-70	90	2138x2590x2021
PCX-1210	200	3-5	60-80	70-90	110	2524x2716x2325
PCX-1212	200	3-5	60-100	70-110	132	2524x2866x2325
PCX-1414	200	5-8	70-150	70-160	200	2550x3120x2670
PCX-1616	200	5-8	100-210	110-260	250	2922x3564x2900
PCX-1818	200	5-10	120-270	130-310	315	3121x3754x3150